

Condensing Unit Technical Data Sheet

Model CGLY12RGb_N
Voltage 200-220/220-230V 50/60Hz ~1
Refrigerant R134a

APPLICATION

Application	High Back Pressure
Refrigerant	R134a
Evaporating Temp.	-15,0 °C to 10,0 °C
Expansion	Capillar/Valve
Comp. Cooling	Fan cooled
Max. ambient temp.	43,0 °C

COMPRESSOR

Displacement	10,70 cm ³
Diameter	25,40 mm
Stroke	21,12 mm
Oil type	ISO VG 32 ESTER
Oil charge	345 cm ³

MOTOR

Nominal Power	3/8 hp
Voltage/Frequency	200-220V 50Hz
Voltage range	170-233 V
Type	CSR
Phase number	1 PH
Locked Rotor Amps (LRA)	17,00 A
Max. Cont. Current (MCC)	4,20 A
Main W. resist. at 25°C	6,30 Ω
Start W. resist. at 25°C	17,00 Ω

NOMINAL PERFORMANCE

Cooling Capacity	1.048 W
COP	1,99 W/W
EER	1,71 kCal/Wh
Input Power	526 W
Current	2,33 A

ASHRAE

TEST CYCLE CONDITIONS

	HBP
Evaporating temp. (T _e)	7,2 °C
Condensing temp. (T _c)	55,0 °C
Liquid temp. (T _{liq.})	46,0 °C
Ambient temp. (T _{amb.})	35,0 °C
Suction temp. (T _{suction})	35,0 °C
Voltage/Frequency	220 V 50 Hz

CONDENSER AND FAN DATA

Condenser type	CU-AL
Condenser model	9T 3R
Fan blade (Ø mm / °)	230 / 28
Fan motor	10W 200V 50/60Hz

WIRING DIAGRAM

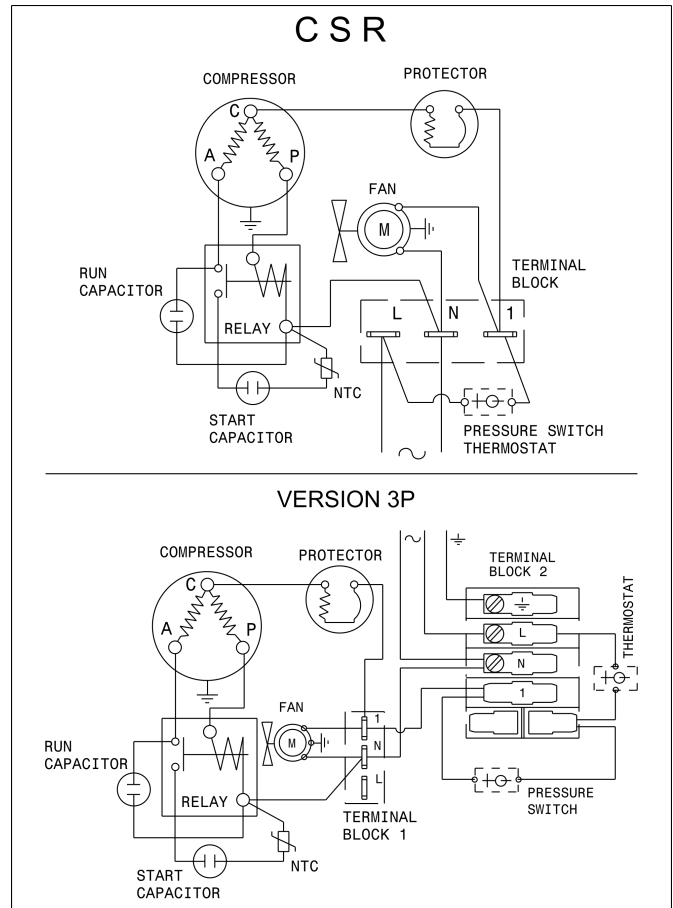

REFRIGERATION CAPACITY (W) Evaporating Temperature (°C)

Model	Motor	-25	-15	-5	5	7.2			10
						W	Winp	A	
CGLY12RGb_N	CSR	-	422	662	971	1048	526	2.33	1151

ASHRAE HBP: Condensing temperature: 55°C, Liquid temperature: 46°C, Suction temperature: 35°C, Ambient temperature: 35°C

Condensing Unit Technical Data Sheet

VERSIONS

VERSION 1	VERSION 2	VERSION 3	VERSION 3P	VERSION 4
Tube	Service valve	Service valve and receiver	Service valve, receiver, pressure switch	Schrader valve on the service port
Suction tube internal diam.: 8,1 mm Discharge tube internal diam.: 6,5 mm Net Weight: 19,7 Kg	Suction valve: 3/8" Discharge valve: 1/4" Net Weight: 20,2 Kg	Receiver vol.: 0,9 l Suction valve: 3/8" Discharge valve: 1/4" Net Weight: 20,5 Kg	Receiver vol.: 0,9 l Suction valve: 3/8" Discharge valve: 1/4" Net Weight: 21,6 Kg	Suction tube internal diam.: 8,1 mm Discharge tube internal diam.: 6,5 mm Net Weight: 19,7 Kg

DIMENSIONS (Version 3 drawing)

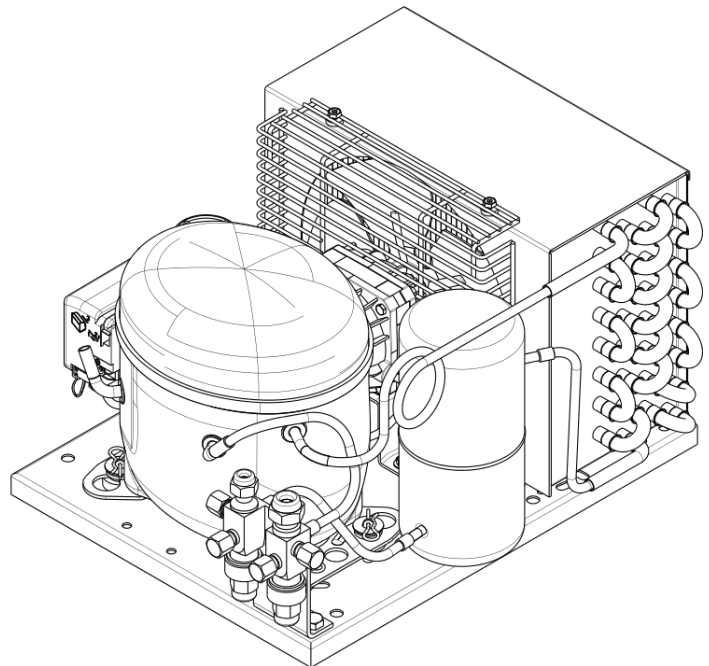
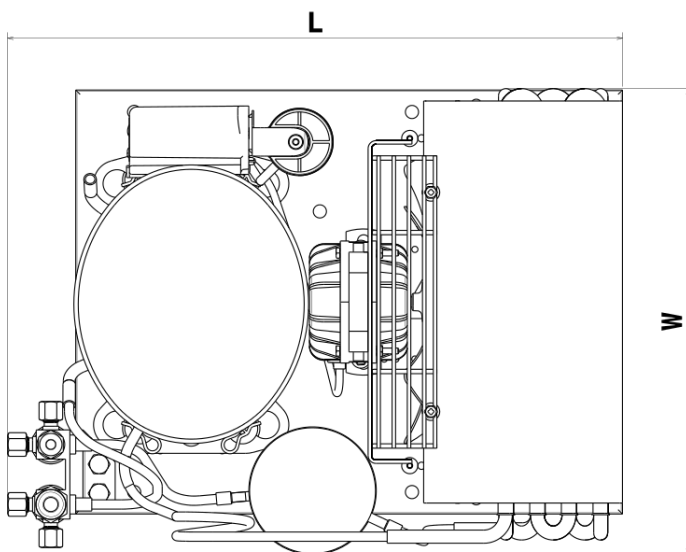
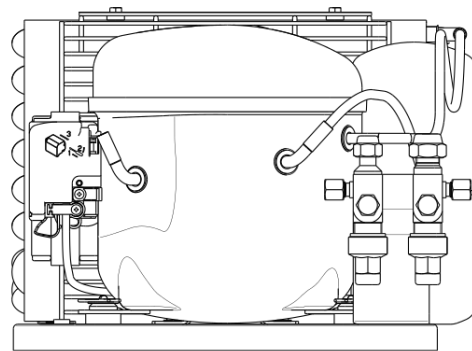
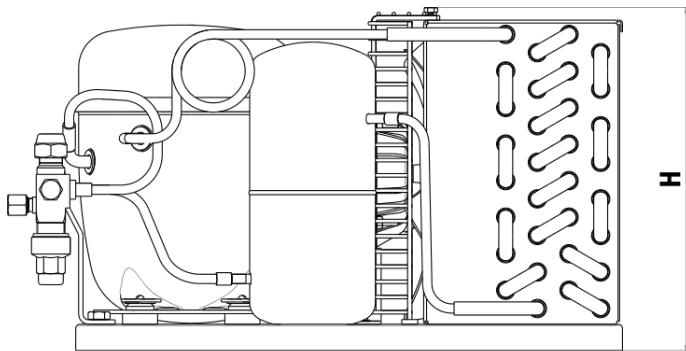

VERSION 1-4 (WxLxH) (mm)	VERSION 2 (WxLxH) (mm)	VERSION 3 (WxLxH) (mm)	VERSION 3P (WxLxH) (mm)
345x385x275	345x425x275	345x425x275	350x435x275