

SL-600 ET

SNACK

SALAMANDER

Salamander - Upper part adjustable - 3 open sides 2 cooking areas - 1 grid 58x34



Construction - Fabricated using CrNi 18/10 AISI 304 grade Stainless Steel Scotch-Brite Satin polish Finish, chromed details. Knobs with waterproof grades IPX5. Model - Professional electric salamanders, ideal for gratinating, grilling and warming food. 3 open sides version with special system for the height regulation of heating elements, a perfect balance in every position for more security. Ceramic glass version with radiant heat hot plates. Maintenance - Easy cleaning by tray at the bottom to collect the fat. Fittings - Supporting feet.



ITALIAN CULINARY ART

The pictures are purely representative. The manufacturer reserves the right to modify the technical data and models without previous notice.

SL-600 ET

SNACK
SALAMANDER

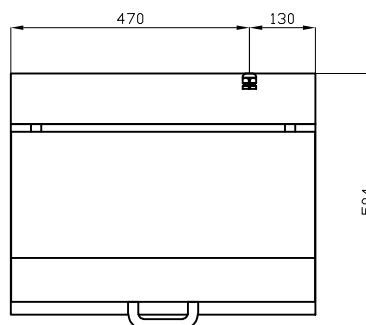
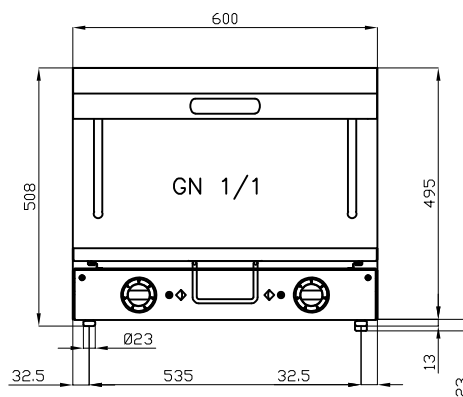
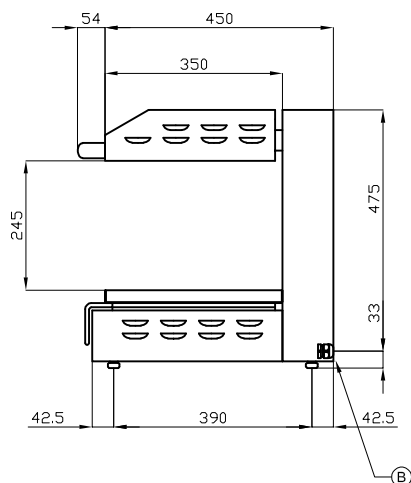

A	Data plate	B	Electrical connection
---	------------	---	-----------------------

MODEL: SL-600 ET
DIMENSIONS: cm. 60x 50x 51h
ELECTRIC POWER: 4 kW
VOLTAGE: 400V~2N / 230V~3
FREQUENCY: 50/60 Hz

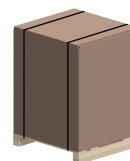

kg: 47
m³: 0.232
mm: 670x540x640

BUY LOTUS BUY ITALY

The pictures are purely representative. The manufacturer reserves the right to modify the technical data and models without previous notice.



LOTUS S.P.A. Via Calmaor, 46
31020 San Vendemiano(TV) - Italy
Tel. + 39 0438 778020 / 778468
Fax + 39 0438 778277
www.lotuscookers.it - lotus@lotuscookers.it