

Range (ATO-4B)



Standard Features

- Stainless steel front, back, sides, kick plate including back guard and high shelf
- Heavy duty lift off cast iron burners rated at 25,000 BTU/hr
- 12"×12" cast iron top grates
- Oven burner rated at 27,000 BTU/hr
- Oven pilot with 100% safety shut off
- Multiple position oven rack guides
- One chrome rack per oven
- Stainless steel tubing for burners and pilots
- 3/4" thick polished steel griddle plate
- 1 year parts and labor



ATO-4B

Specifications

Gas type	Intake-tube Pressure (in.W.C.)	Ignition Way	Burner name	Nozzle No	Per BTU B.T.U./h	Burners QTY (pcs)	Total BTU B.T.U./h	Oven QTY	Oven size (CM)	Griddle working area (CM)	Hot plates working area (inch)	Valve Types	Temp. Control	Net Weight (KG)	Exterior Size (CM)	
LP	10	Manually	Hot plates	LP54	23000	4	116000	1	50x66x35	None	4pcs 11 4/5" x 11 4/5"	Pilot light	Only the oven	137	61 x 79 x 143 (93 + 50)	
			Griddle	U-SHAPE	LP52	27000										0
				I-SHAPE	LP54	21000										0
			Oven	LP53	24000	1										

Plan View

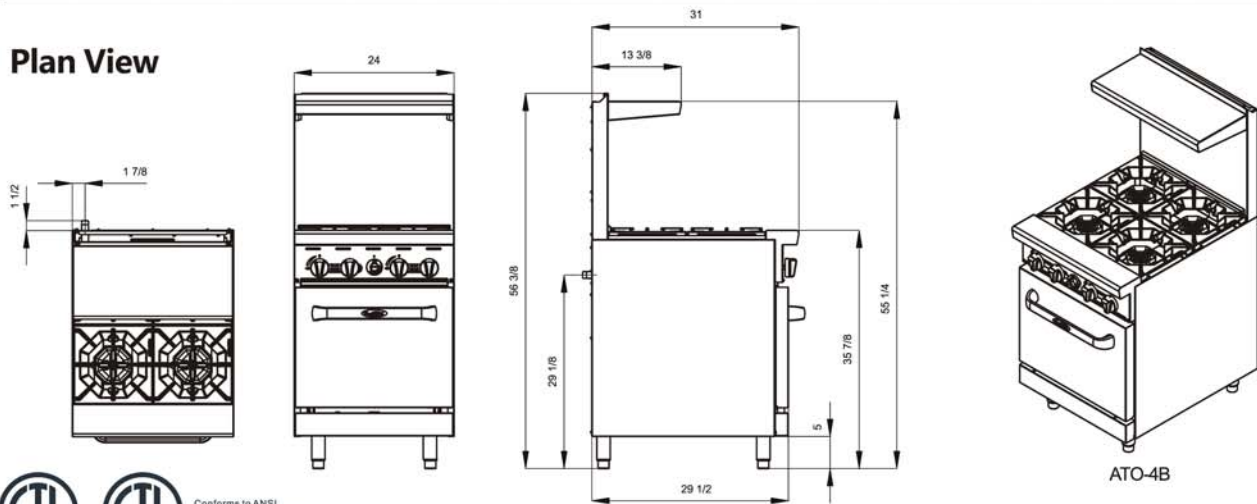

ATO-4B

